

This design is based on the 1916 Boucher model of the *Flying Cloud* in the Boston Museum of Fine Arts. The *Flying Cloud* had 2 companionways, one over the aft hatch and one on the poop deck in front of the binnacle. The coaming for the poop deck companionway was 8.5" high above the deck at the aft end and followed the deck profile to the fore end. The companionway over the aft hatch was tied down to rings on deck. This companionway could be removed while the *Flying Cloud* was loaded or unloaded.

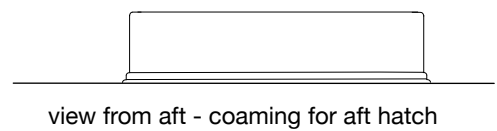

window frames - mahogany
 roof boards - sky blue
 doors - oak
 sliding hatch cover - mahogany
 hatch cover slides - oak
 rest of structure - white

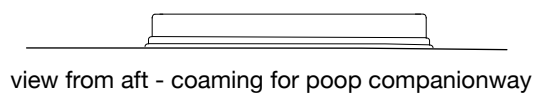
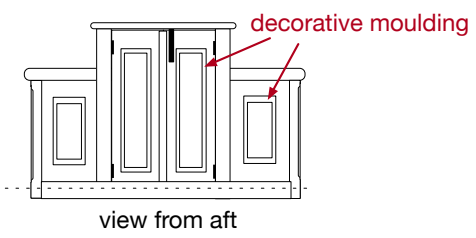
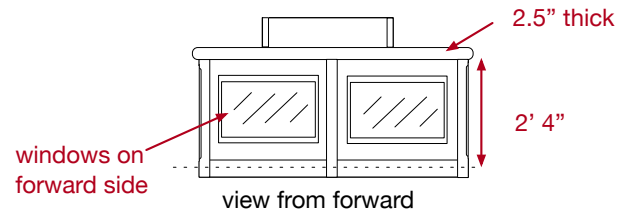
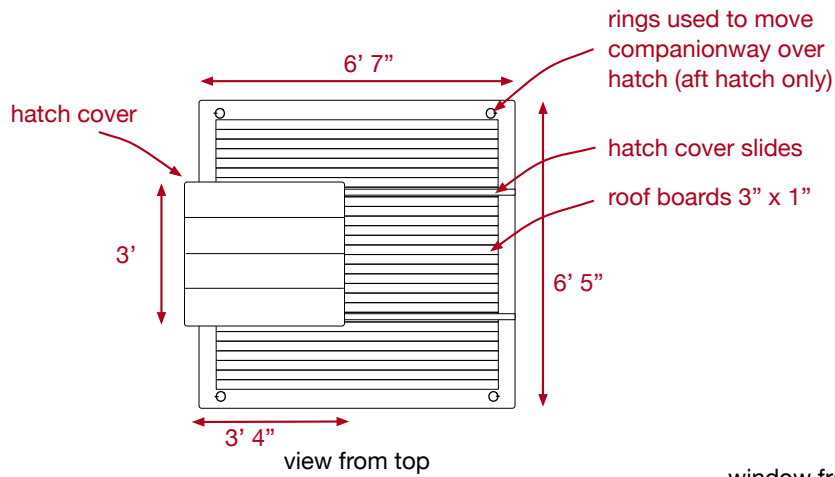
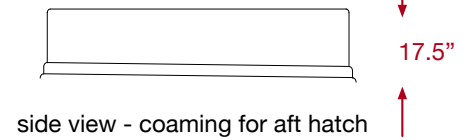
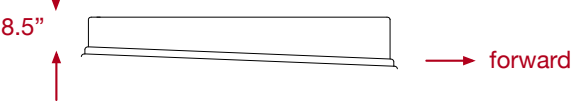
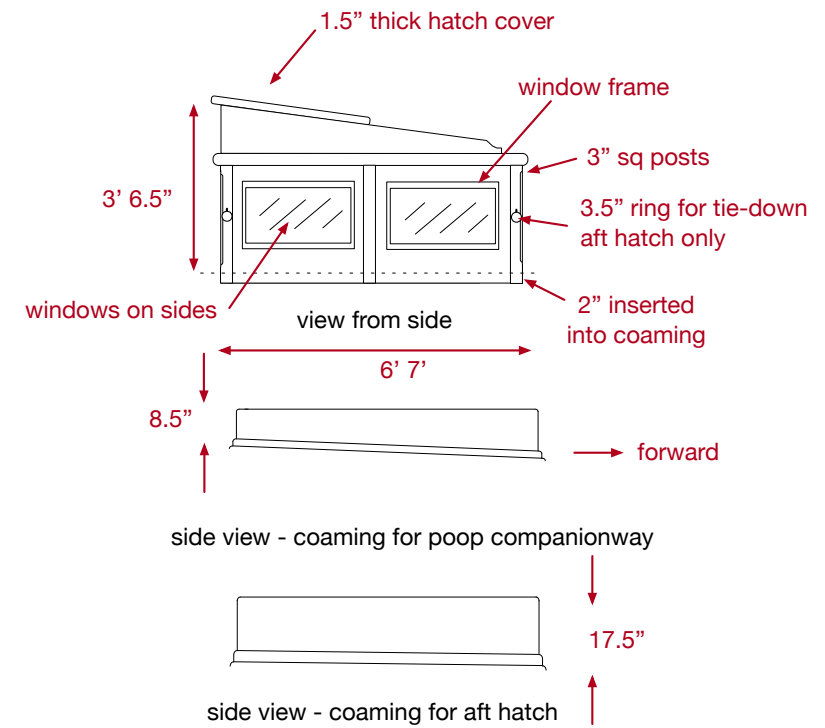
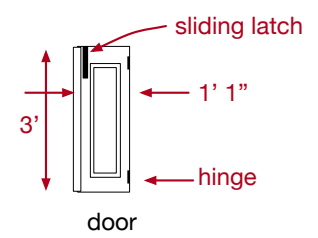
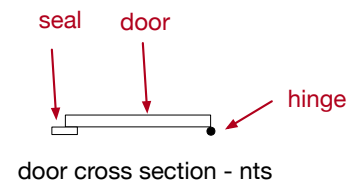

FLYING CLOUD - COMPANIONWAYS

nts = not to scale