

The shapes and sizes of this binnacle and steering gear cover are based on the Boucher 1916 model of the *Flying Cloud* in the Boston Museum of Fine Arts. The steering wheel size and details are based on the wheel on the *Cutty Sark* since there is no way to know just what the original wheel looked like on the *Flying Cloud*. Steering wheels at the time seem to have had 8 or 10 spokes.

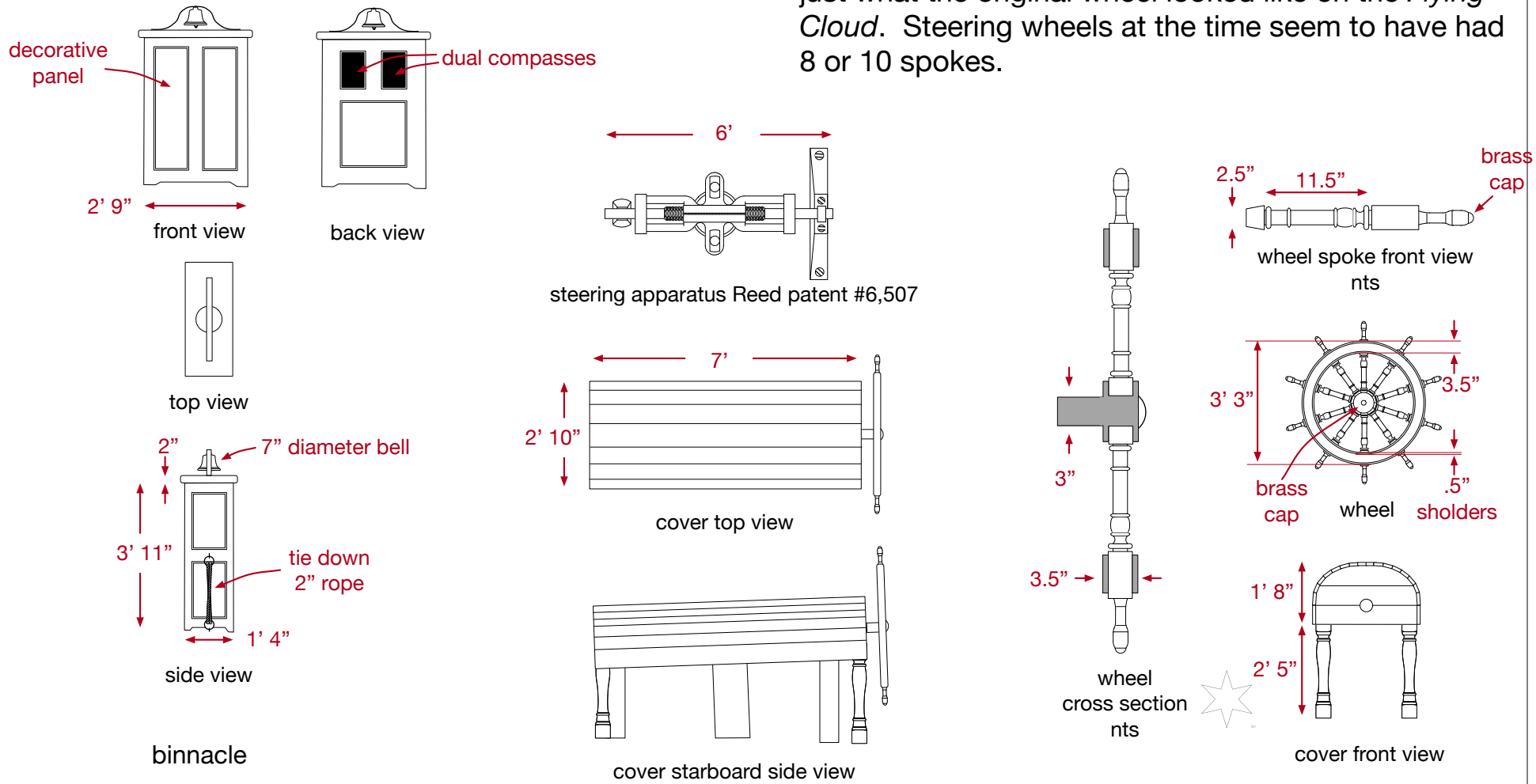

nts = not to scale

### FLYING CLOUD - STEERING GEAR COVER AND BINNACLE