

The design of this windlass is based on Paasch plate 70 with some details from Campbell figure 46 and pages 129-132. Dimensions and additional details from the windlass on the *Charles W. Morgan* in Mystic Seaport.

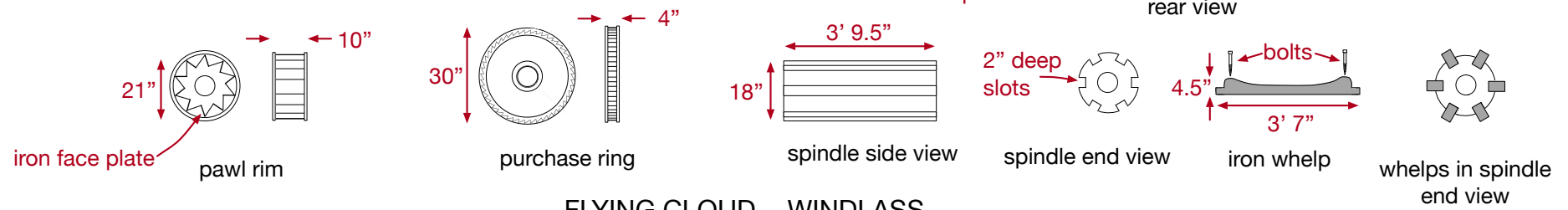
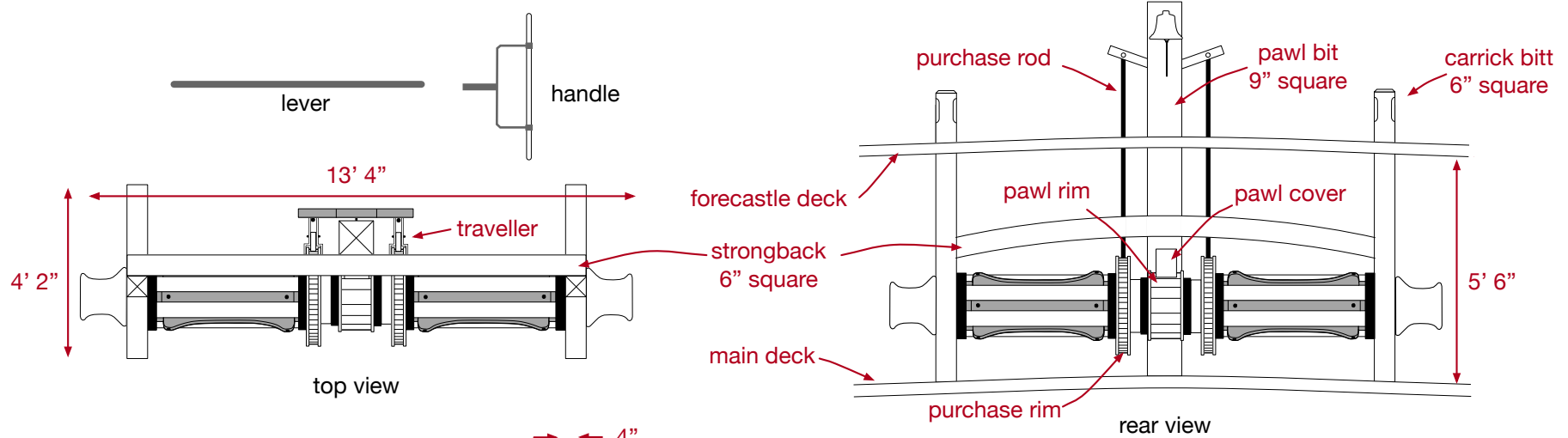

FLYING CLOUD - WINDLASS